

1000 Series

Brush, Rotary DC Servomotors

Dynamically balanced, skewed rotor for exceptionally smooth velocity

Standard NEMA 23, 34, and 42 frame sizes

Standard stainless-steel shaft resists corrosion

Double shielded bearing for long motor life

Options include tachometer, encoders, metric flange, and integral cable



The 1000 series motors are Aerotech's high-performance brush-type rotary DC servomotors. These motors are designed for a variety of general and high-performance motion control applications. Custom mechanical or electrical configurations are also available with minimal lead time.

Skewed Rotor

The 1000 series DC motors feature a dynamically-balanced skewed rotor and tachometer assembly for less cogging and smoother velocity control. The skewed laminations help reduce the effects of torque ripple that can cause velocity disturbance. The result is a much smoother velocity profile for such applications as machine tool, medical, semiconductor, and scanning.

Standard NEMA Frames

The 1000 series motors come in standard NEMA frame sizes including 23, 34, and 42. The standardized flange and shaft dimensions make it easy to mount to existing NEMA-based machines.

Each motor is constructed from high-grade materials including a stainless-steel shaft, double-shielded bearings, and precision machined housing. Full burn-in of each motor ensures long-term reliable operation.

Wide Torque Range

The 1000 series DC motors cover a wide range of torque to meet virtually all high-end DC motor applications. Continuous output torque ranges from 0.25 N-m (35 oz-in) to 1.48 N-m (210 oz-in). Peak output torque ranges from 1.84 N-m (260 oz-in) to 7.1 N-m (1000 oz-in).

Customized Applications

Standard motor models are available with and without a DC tachometer in different voltage gradients. Options include alternate windings, metric shafts and flanges, encoders with line driver or amplified sine-wave output, rear housings with integral cables, or MS-style heavy-duty connectors.

1000 Series SPECIFICATIONS

Motor Model	Units	1035	1050	1135	1210
Performance Specifications					
Stall Torque, Continuous	N-m (oz-in)	0.25 (35)	0.35 (50)	0.95 (135)	1.48 (210)
Peak Torque	N-m (oz-in)	1.84 (260)	2.52 (355)	5.22 (736)	7.1 (1000)
Maximum Speed	rpm	6,000	6,000	5,000	3,000
Rated Power	W (hp)	129 (0.2)	146 (0.2)	200 (0.3)	220 (0.3)
Electrical Specifications					
Winding Designation		-01	-01	-01	-01
Continuous Stall Current	Amps	4.1	5.4	5.5	6.0
Torque Constant	N-m/Amp (oz-in/Amp)	0.06 (8.5)	0.07 (9.3)	0.17 (24.5)	0.25 (35.0)
Terminal Resistance	ohms	0.9	0.7	1.4	1.8
BEMF Constant	V _{pk} /krpm	6.3	6.9	18.2	25.9
Armature Inductance	mH	2.0	2.5	3.1	4.9
Armature Moment of Inertia	kg-m ² (oz-in-s ²)	3.8x10 ⁻⁵ (0.005)	5.7x10 ⁻⁵ (0.008)	3.5x10 ⁻⁴ (0.052)	9.2x10 ⁻⁴ (0.13)
Recommended Bus Voltage	VDC	40	40	80	80
Maximum Terminal Voltage	VDC	72	72	104	137
Motor Constant	N-m/√W (oz-in/√W)	0.063 (9.0)	0.084 (11.1)	0.14 (20.7)	0.17 (26.1)
Mechanical Specifications					
Frame Size	NEMA	23	23	34	42
Motor Weight Without Tach	kg (lb)	1.2 (2.5)	1.6 (3.5)	3.7 (8.1)	4.1 (9.0)
Motor Weight With Tach	kg (lb)	1.6 (3.5)	2.1 (4.5)	4.6 (10.1)	5.2 (11.5)
Shaft Radial Load (Max) at Max Speed	N (lb)	44 (10)		89 (20)	134 (30)

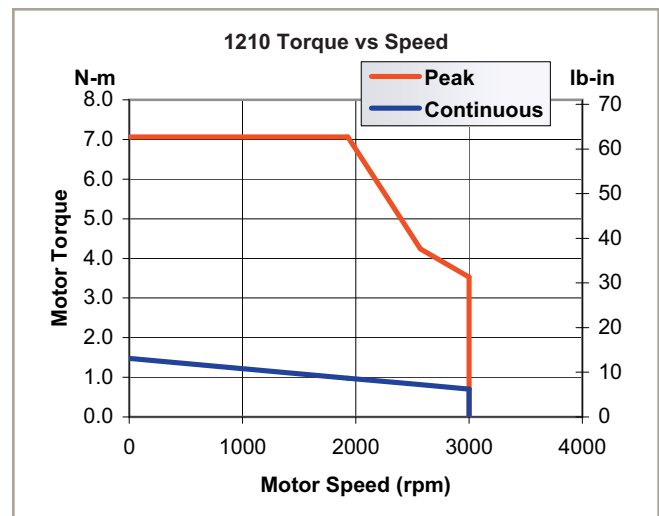
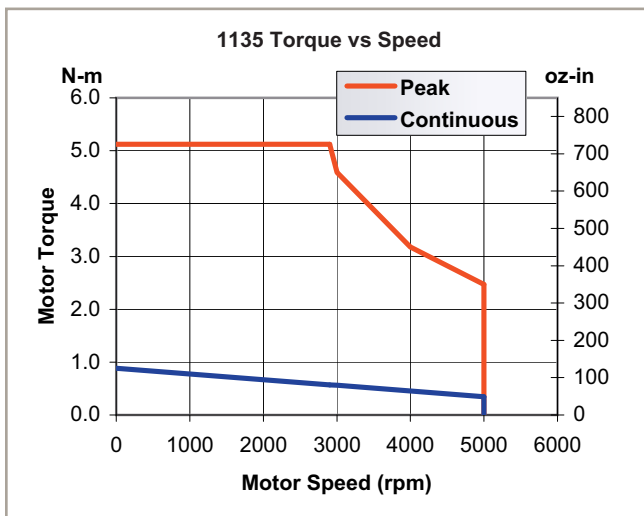
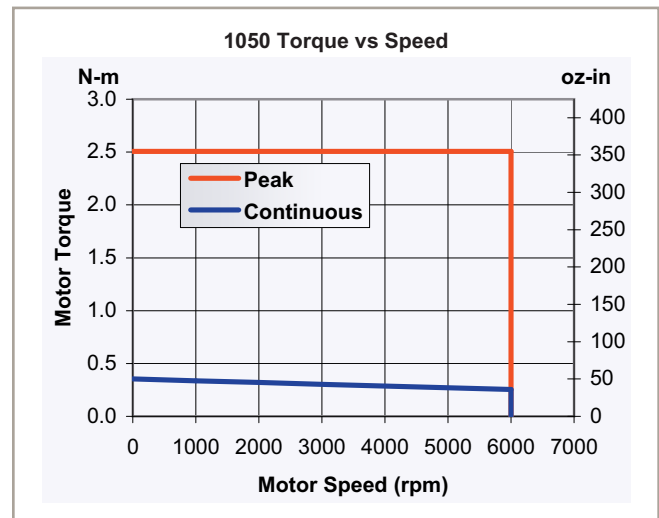
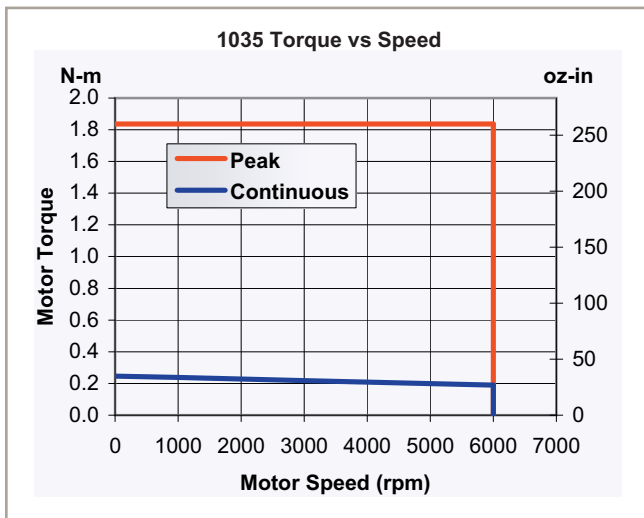

1000 Series DIMENSIONS

NEMA 23

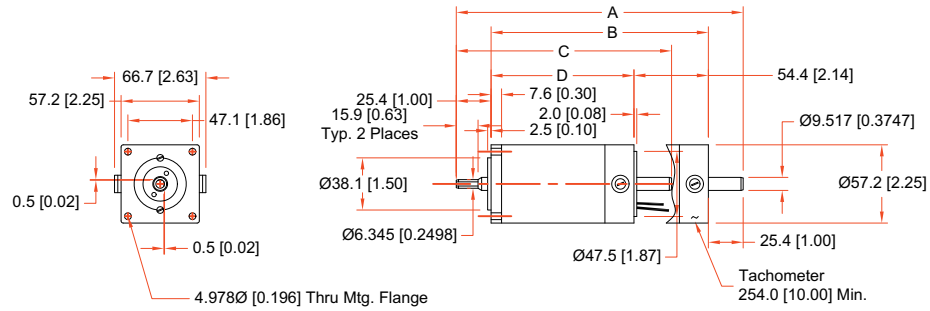

Model Name	Dimensions - Millimeters [Inches]			
	A	B	C	D
1035LT	-	-	157.2 [6.19]	104.4 [4.11]
1050LT	-	-	177.5 [6.99]	124.7 [4.91]
1035DC	209.6 [8.25]	158.8 [6.25]	-	-
1050DC	229.9 [9.05]	179.1 [7.05]	-	-

NEMA34

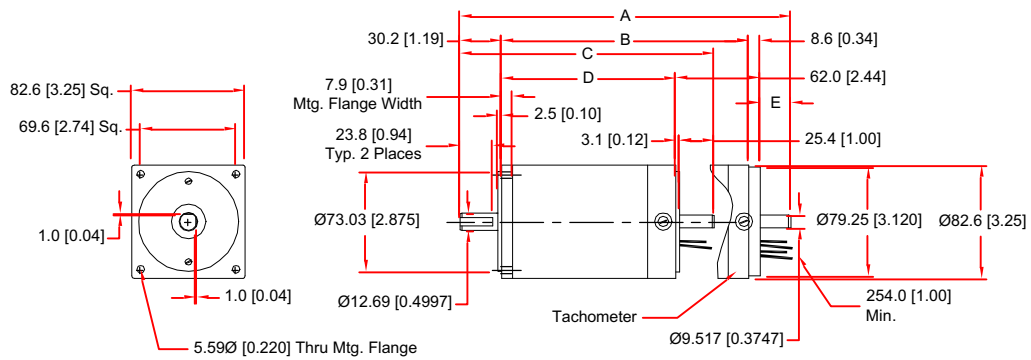

Model Name	Dimensions - Millimeters [Inches]				
	A	B	C	D	E
1135DC	278.1 [10.95]	215.4 [8.48]	-	-	23.9 [0.94]
1135LT	-	-	220.7 [8.69]	162.1 [6.38]	-

NEMA42

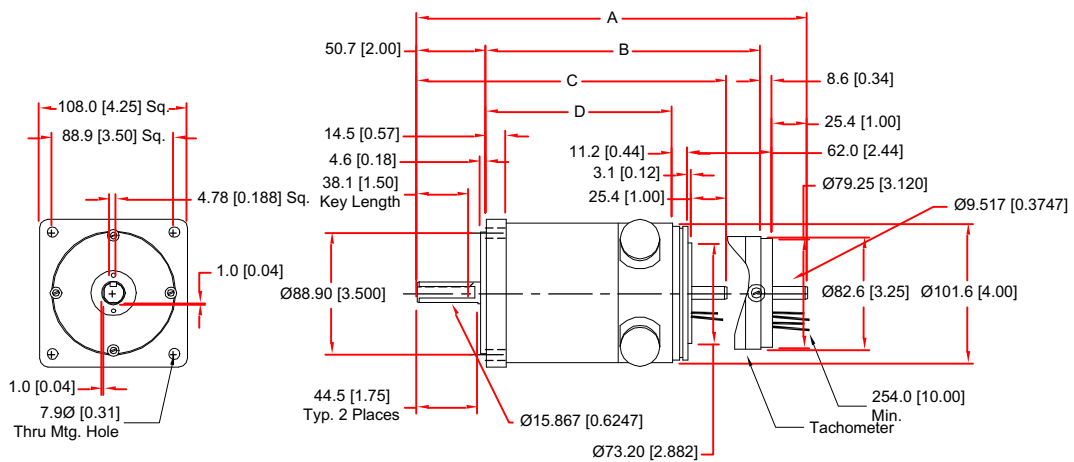

Model Name	Dimensions - Millimeters [Inches]			
	A	B	C	D
1210DC	285.0 [11.22]	200.2 [7.88]	-	-
1210LT	-	-	226.1 [8.90]	135.6 [5.34]

NEMA 23 Motor Cans

MS01: End-Exit Connector

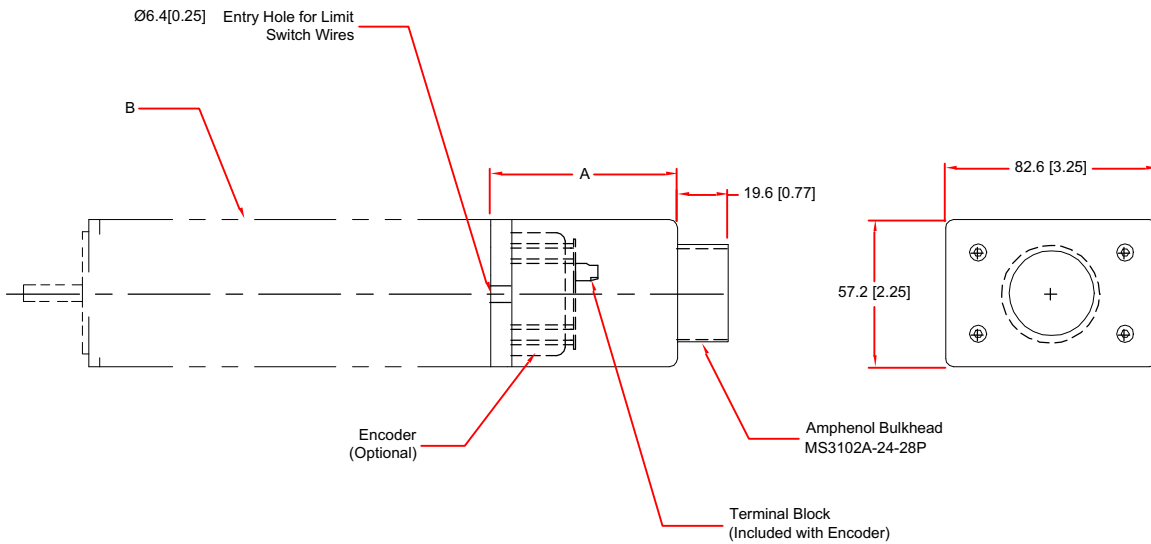

Dimensions - millimeter [inches]

A	B
72.6 [2.86]	1035LT 1050LT
73.9 [2.91]	1035DC 1050DC

MS0F: Side-Exit Connector

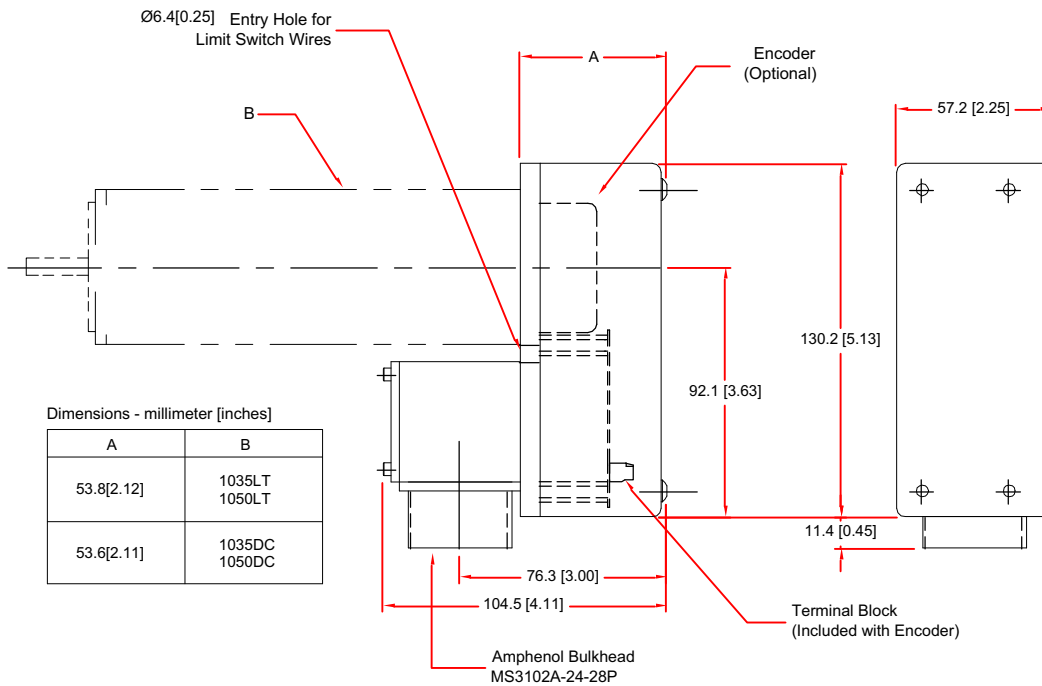

Dimensions - millimeter [inches]

A	B
53.8 [2.12]	1035LT 1050LT
53.6 [2.11]	1035DC 1050DC

NEMA 34 Motor Cans

MSO1: Side-Exit Connector

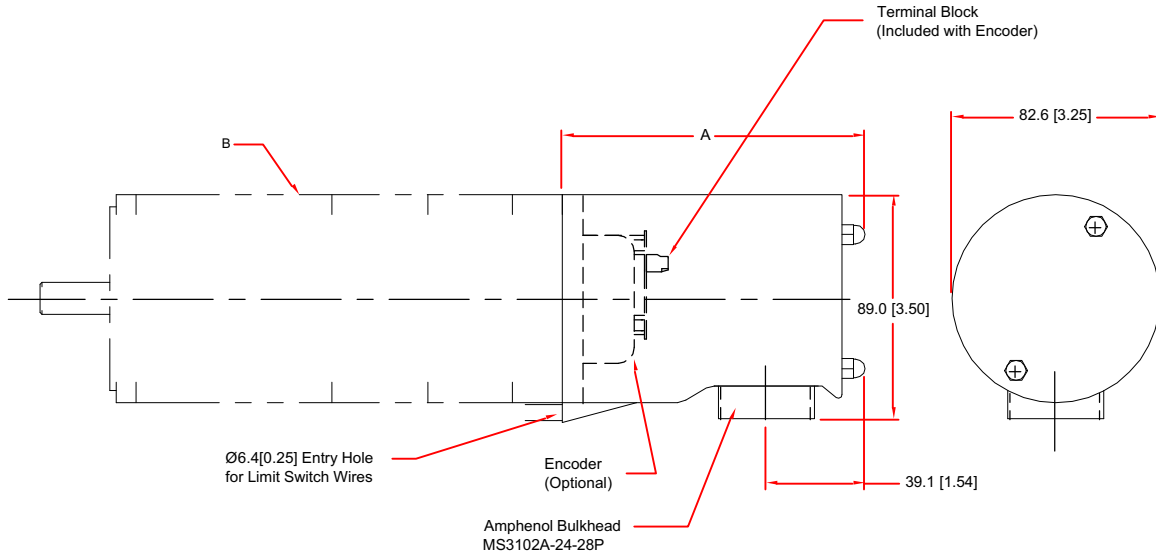

Dimensions - millimeters [inches]

A	B
123.2[4.85]	1135LT
120.0[4.73]	1135DC

MSOF: Side-Exit Connector

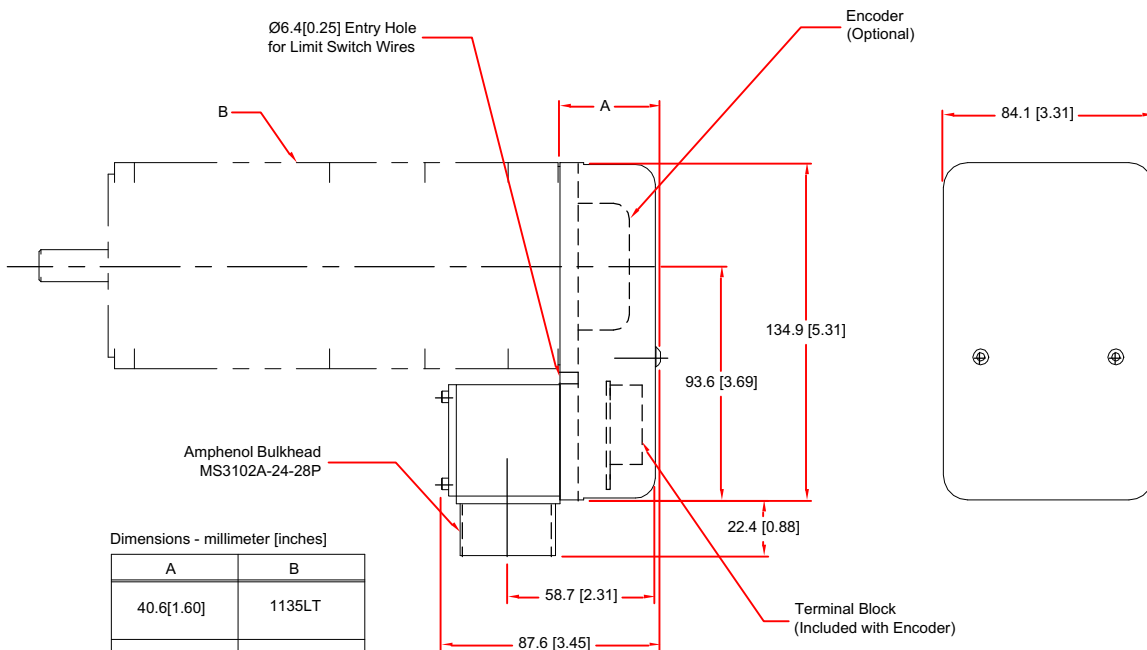

Dimensions - millimeter [inches]

A	B
40.6[1.60]	1135LT
39.6[1.56]	1135DC

NEMA 42 Motor Cans

MSO1: Side-Exit Connector

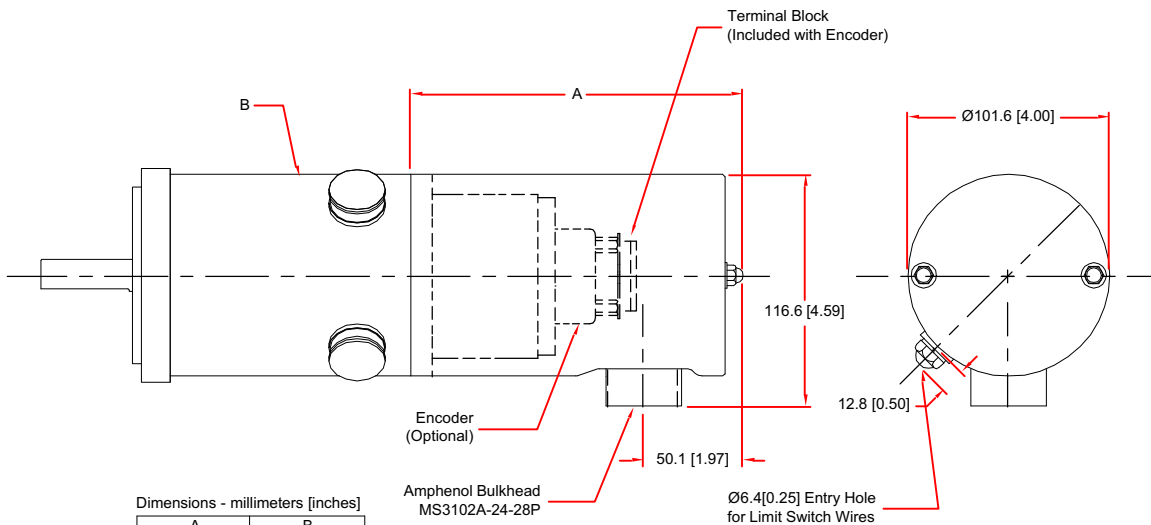

MST: Side-Exit Conduit Fitting

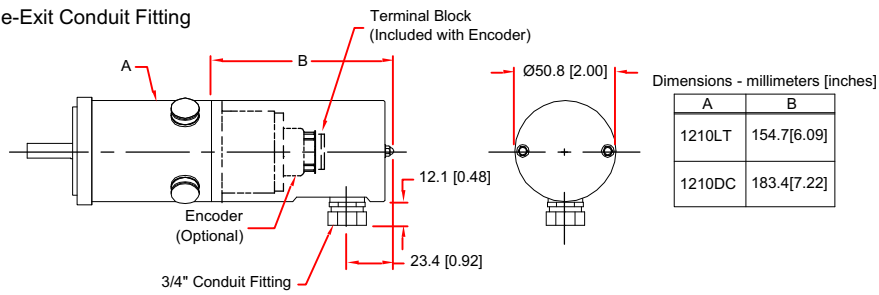

1000 Series ORDERING INFORMATION

Ordering Example

1	135	DC	MSOF	E2000	AS
Model	Motor Size (continuous torque in oz-in)	Tachometer Option	Termination	Encoder Line Count Per Revolution	Encoder Output
	035, 050, 135, 210	DC, LT	(none), MSO1, MSOF, MST, DC2, DC3, DC3E, W100	200, 500, 1000 (std), 1250, 2000	LD, AS

2 1/4" Diameter, NEMA 23 Models

1035LT	Tcont = 0.25 N-m (35 oz-in) DC servomotor
1035DC	Tcont = 0.25 N-m (35 oz-in) DC servomotor with 3V/krpm tachometer
1050LT	Tcont = 0.35 N-m (50 oz-in) DC servomotor
1050DC	Tcont = 0.35 N-m (50 oz-in) DC servomotor with 3V/krpm tachometer

Options, NEMA 23 Models

-E200AS - E1000AS	Encoder, 3 channel, amplified sine output
-E2000AS	High density encoder, 3 channel, amplified sine output
-E200LD - E1000LD	Encoder, 3 channel, line driver output
-E2000LD	High density encoder, 3 channel, line driver output
-DC2	Rear housing, side-exit integral cable with connector (LT motor only)
-DC2E	Rear housing, end-exit integral cable with connector
-MSO1	Rear housing, end-exit connector
-MSOF	Rear housing, side-exit connector
-VAC	Vacuum preparation of motor or motor-tach to 10 ⁻⁶ Torr
-02 or -03	Non-standard tachometer winding

3 1/4" Diameter, NEMA 34 Models

1135LT	Tcont = 0.95 N-m (135 oz-in) DC servomotor
1135DC	Tcont = 0.95 N-m (135 oz-in) DC servomotor with 3V/krpm tachometer

Options, NEMA 34 Models

-E200AS - E1000AS	Encoder, 3 channel, amplified sine output
-E2000AS	High density encoder, 3 channel, amplified sine output
-E200LD - E1000LD	Encoder, 3 channel, line driver output
-E2000LD	High density encoder, 3 channel, line drive output
-DC3	Rear housing, side-exit integral cable with connector
-MSO1	Rear housing, side-exit connector
-MSOF	Rear housing, right angle low-profile with side-exit connector (shorter than MSO1)
-VAC	Vacuum preparation of motor or motor-tach to 10 ⁻⁶ Torr
-02 or -03	Non-standard tachometer winding

4" Diameter NEMA 42 Models

1210LT	Tcont=1.48 N-m (210 oz-in) DC servomotor
1210DC	Tcont=1.48 N-m (210 oz-in) DC servomotor with 3V/krpm tachometer

Options (NEMA 42 Models)

E200AS - E1000AS	Encoder, 3 channel, amplified sine output
E2000AS	High density encoder, 3 channel, amplified sine output
E200LD - E1000LD	Encoder, 3 channel, line driver output
E2000LD	High density encoder, 3 channel, line driver output
-MSO1	Rear housing, side-exit connector
-MST	Rear housing, side-exit conduit fitting
-VAC	Vacuum preparation of motor or motor-tach to 10 ⁻⁶ Torr
-02 or -03	Non-standard tachometer winding